

CHALK CONTAINER M'2007**2860A****KEEP THIS
DOCUMENT****Warning:**

This equipment should be installed by a qualified individual.
Using this equipment for purposes other than those originally intended is not allowed.
It is advised not to lean on nor to seat on the upper part of the chalk container.

Recommendations:

As shown in French Standard NF S52-400 the following is recommended:

- keep these instructions for subsequent reference (inspection, maintenance, etc.).
- periodically carry out predictive maintenance.
- depending on how much it is used, have the equipment serviced yearly or every few years.

Chalk container assembly (see Figures 1 & 2):

Note: Prepare a clean area for assembling the chalk container.

- 1** - Put down on the floor the "A" foot **(1)** and put the lower part of the "V" upright **(2)** in the 2 notches located in the centre of the "A" foot **(1)**. Turn inside out and fix them together with the 2 wooden screws **(5)** and the supplied hexagon spanner **(7)**.
- 2** - Put down on the floor again the partially assembled foot. Install the transparent bowl **(4)**: insert the 2 holes of the bowl **(4)** edge in the 2 metal axis **(6)** of the upper part of "V" upright **(2)** (see **Fig. 2**).
- 3** - Put the "G" support **(3)** in the "V" upright **(2)**. Be careful to assemble the "G" support **(3)** in the right side to read "G" and "A" on the same way.
- 4** - Before screw, check that the transparent bowl **(4)** does not get out from the 2 metal axis **(6)** during the last operation. Otherwise, put again correctly the bowl, like explained before (N° **2**). Fix them together with the 2 wooden screws **(5)** and the supplied hexagon spanner **(7)**.

Packaging:

- 1 package (ref.: 2860/00): chalk container supports

Weight: 6 kg (13.23 lb) Dimensions: 880 x 560 x 100 mm (2.89 x 1.84 x 0.33 ft) Volume: 0,0493 m³ (1.741 ft³)

- 1 package (ref.: 2860/41): chalk container bowl

Weight: 2 kg (4.41 lb) Dimensions : 450 x 450 x 450 mm (1.48 x 1.48 x 1.48 ft) Volume : 0,0911 m³ (3.217 ft³)

Figure 1

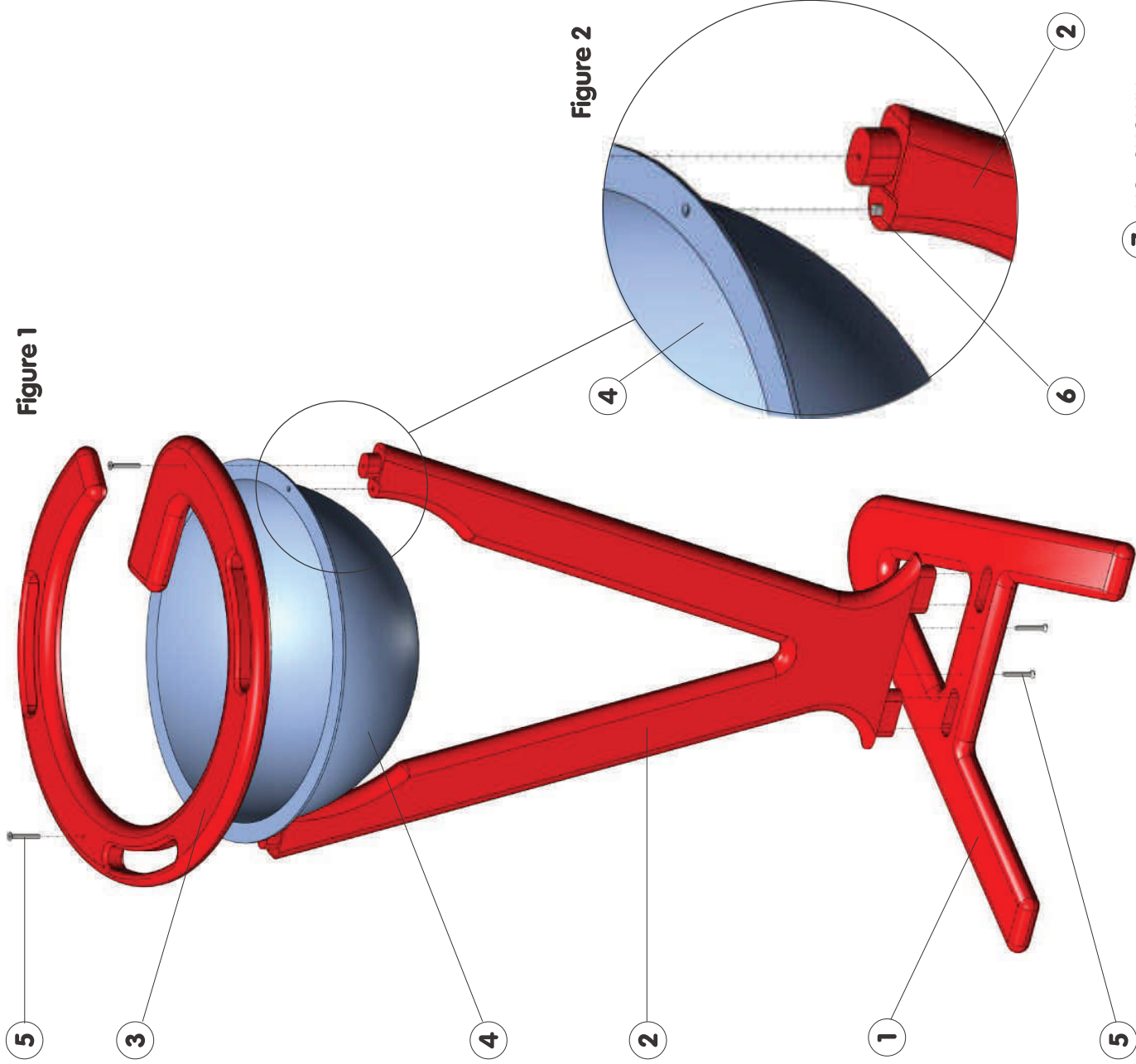

30	-	-	-	-
29	-	-	-	-
28	-	-	-	-
27	-	-	-	-
26	-	-	-	-
25	-	-	-	-
24	-	-	-	-
23	-	-	-	-
22	-	-	-	-
21	-	-	-	-
20	-	-	-	-
19	-	-	-	-
18	-	-	-	-
17	-	-	-	-
16	-	-	-	-
15	-	-	-	-
14	-	-	-	-
13	-	-	-	-
12	-	-	-	-
11	-	-	-	-
10	-	-	-	-
9	-	-	-	-
8	-	-	-	-
7	1	Hexagon spanner	-	-
6	2	Metal axis	-	included in (2)
5	4	ø5x50 wooden screw	-	-
4	1	Transparent drilled bowl	2860/41	-
3	1	Chalk container "G" support	2860/10	-
2	1	Chalk container "V" upright	2860/20	> pack. 2860/00
1	1	Chalk container "A" foot	2860/30	-
ITEM	QTY	DESCRIPTION	REFERENCE	REMARKS

Gymnova

RUE GASTON DE FLOTTE
13012 MARSEILLE
Tél. : 33-(0)-4-91-87-51-20
Fax : 33-(0)-4-91-93-86-89

CHALK CONTAINER M'2007

7 NOT SHOWN

NM242

DATE: 09/06/08

Ref. : 2860A

Pour commander les pièces détachées, rappeler la désignation, la référence et la date de livraison de l'appareil complet.

THIS DOCUMENT IS THE PROPERTY OF GYMNOVA. IT IS CONFIDENTIAL AND SHALL NOT BE REPRODUCED WITHOUT PRIOR AUTHORIZATION.