

GYMNOVACS 30056 - 45 RUE G. DE FLOTTE
13375 MARSEILLE CEDEX 12 (FRANCE)
TEL : 33.(0)4.91.87.51.20 FAX : 33.(0)4.91.93.86.89
WWW.GYMNOVA.COM**ASSEMBLY INSTRUCTIONS**

NM254F-GB

11/01/21

**14x14M & 13x13M OVERLAY CARPETS
AND ARTISTIC GYMNASTICS EXERCISE FLOORS****6380H**
6570J-6775D-6775D/DE
6390I
6565K-6777D-6777D/DE**6570J &
6775D - 6775D/DE****KEEP THIS
DOCUMENT****Warning:**

This equipment should be installed by a qualified individual. This equipment should only be used by one person at a time, under the supervision of a qualified individual.
Using this equipment for purposes other than those originally intended is prohibited.

Compliance:

14 x 14 m Exercise floors references **6570J, 6775D et 6775D/DE** are FIG approved.

Recommendations:

- Keep these instructions for subsequent reference (inspection, maintenance, etc.).
- Periodically carry out predictive maintenance.
- Depending on how much it is used have the equipment serviced yearly or every few years.

Pack list:

PACK REF.	6380/141 Carpet left side width No. 1 14 x 4m	6380/142 Carpet central width No. 2 14 x 3m	6380/143 Carpet central width No. 3 14 x 3m	6380/144 Carpet right side width No. 4 14 x 4m	6380/108 Set of 3 hook-and- loop joining strips 14m	6532B Carpet Anti-Rotation Kit	No. of Packages
6380H Overlay carpet 14 x 14m	1	1	1	1	1	1	6
VOLUME (M³)	0,62	0,48	0,48	0,62	0,02	0,01	X
WEIGHT (KG)	99	75	75	99	2	1,55	
DIM. (MM)	4300x380x380	3350x380x380	3350x380x380	4300x380x380	370x270x200	300x200x170	

PACK REF.	6390/141 Carpet left side width No. 1 13.05 x 3.52m	6390/142 Carpet central width No. 2 13.05 x 3m	6390/143 Carpet central width No. 3 13.05 x 3m	6390/144 Carpet right side width No. 4 13.05 x 3.52m	6380/108 Set of 3 hook-and- loop joining strips 14m	6532B Carpet Anti-Rotation Kit	No. of Packages
6390I Overlay carpet 13 x 13m	1	1	1	1	1	1	6
VOLUME (M³)	0,55	0,48	0,48	0,55	0,02	0,01	X
WEIGHT (KG)	82	72	72	82	2	1,55	
DIM. (MM)	3800x380x380	3300x380x380	3300x380x380	3800x380x380	370x270x200	300x200x170	

Constantly aiming to improve our products, we reserve the right to make changes to the equipment and dimensions without further discussion.

I. Assembling the floor and the Anti-Rotation Kit:

Refer to assembly instructions NM06 + NM206 for Refs: 6580B & 6595B, NM273 + NM277 for Refs: 6785A & 6787A or NM274 + NM277 for Refs: 6781A & 6783A.

II. Assembling the impact-absorbing foam area and the finishing bibs of springs floors:

Refer to assembly instructions NM253 for Refs: 6542A & 6572A, or NM299 for Refs: 6788B & 6784B.

III. Assembling the overlay carpet: minimum.

Note: Keep the 4 cardboard core tubes flat for any future storage or moving of the carpet (without a reel trolley).

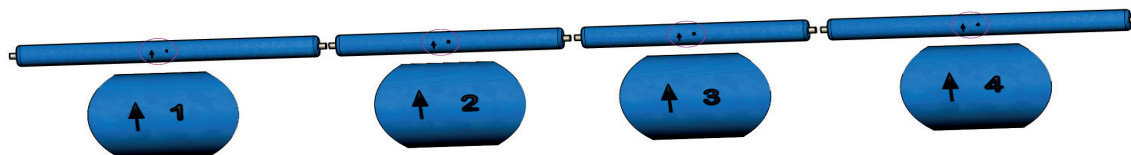

Important: In order to achieve an identical colour shade between the 4 widths (the same pile direction), simply place the 4 rolls side by side observing the order of the numbers and the direction of the arrows (marked on the packaging), as shown in the diagram above.

1/ UNROLL THE 4 WIDTHS OF CARPET RIGHT SIDE UP OVER THE FOAM: IN THE DIRECTION OF THE BLACK STRIP ON THE FOAM TRACKS (SEE FIG. 1, 2 & 3 OR 4, 5 & 6), PLACING THE 2 WIDER ONES TOWARDS THE OUTSIDE. START BY PLACING ONE OF THE 2 LARGE ROLLS (1, 1' OR 4, 4') ON ONE SIDE OF THE FOAM (LARGE RED EDGE TOWARDS THE OUTSIDE):

- 14 x 14 m Exercise floors (Ref.: 6570J, 6775D & 6775D/DE): the 4 m wide side widths (1) and (4) (see Fig. 1 to 3).
- 13 x 13 m Exercise floors (Ref.: 6565K, 6777D & 6777D/DE): the 3.52 m wide side widths (1') and (4') (see Fig. 4 to 6).

2/ REPEAT THIS STEP FOR THE SECOND LARGE ROLL, THEN UNROLL THE CENTRAL WIDTHS (2) AND (3) OR (2') AND (3') IN THE MIDDLE BETWEEN THE OTHER TWO.

3/ POSITION THE FIRST SIDE WIDTH RELATIVE TO THE FOAM AREA, ALIGNING IT WITH THE INITIAL MARKING (14 x 14 m OR 13 x 13 m):

- 14 x 14 m Exercise floor with foam blocks (Ref.: 6570J): the complete carpet overlaps by 25 cm all around the foam (see Fig. 1 & 2).
- 13 x 13 m Exercise floor with foam blocks (Ref.: 6565K): the complete carpet overlaps by 20 cm all around the foam (see Fig. 4 & 5).
- 14 x 14m & 13x13m Sprung Exercise floors (Ref.: 6775D, 6777D, 6775D/DE & 6777D/DE) : the complete carpet does not overlap the foam (see Fig. 1 & 3 for 14 x 14 m exercise floor, Fig 4 & 6 for 13 x 13 m exercise floor).

4/ ADJUST THE 4 WIDTHS SIDE BY SIDE TO FIT PERFECTLY TOGETHER. IN ORDER TO MOVE A WIDTH, ALL THAT'S REQUIRED IS TO HAVE ONE PERSON AT EACH END OF THE WIDTH AND TO LIFT IT ALTERNATELY IN ORDER TO FORCE AIR IN WAVES UNDER THE WIDTH. READJUST ITS POSITION BY PULLING IN THE DESIRED DIRECTION.

Direction of the foam tracks (in green) / Direction of carpet widths (in red)

Figure 1 - 14 x 14m Complete carpet (Ref.: 6380H)

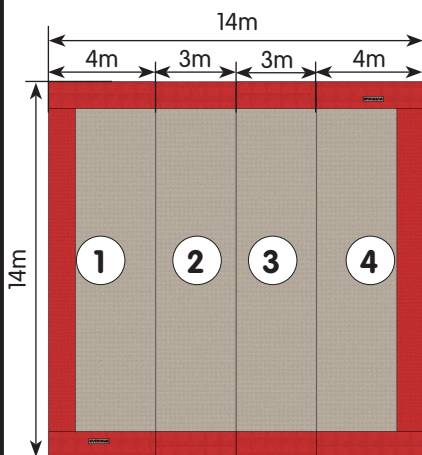

Figure 2 - 13,50 x 13,50m th. 4cm Complete foam "concertina" tracks Ex. Floor with foam blocks (Ref.: 6542A)

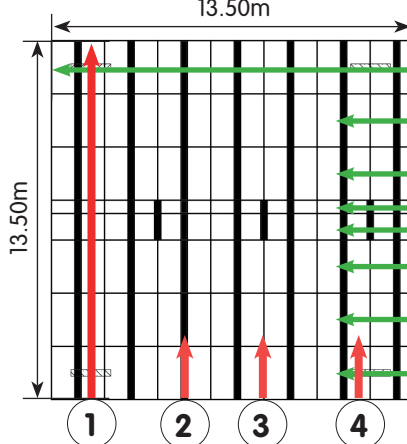

Figure 3 - 14 x 14m th. 5.6cm Complete foam "concertina" tracks Sprung Ex. Floor (Ref.: 6788B)

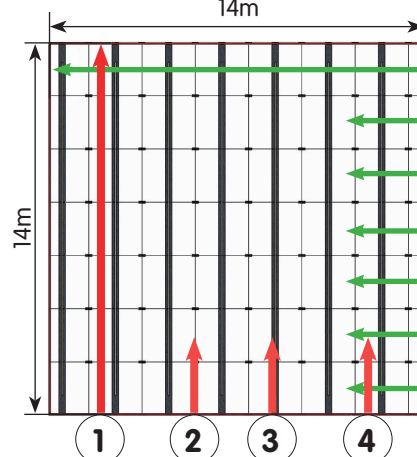

Figure 4 - 13.05 x 13.05m Complete carpet (Ref.: 6390I)

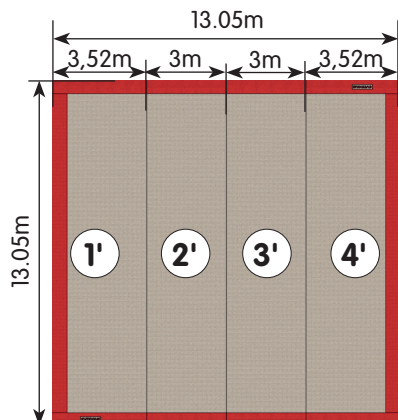

Figure 5 - 12,60 x 12,60m th. 4cm Complete foam "concertina" tracks Ex. Floor with foam blocks (Ref.: 6572A)

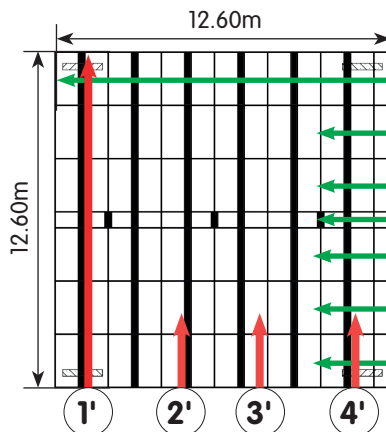
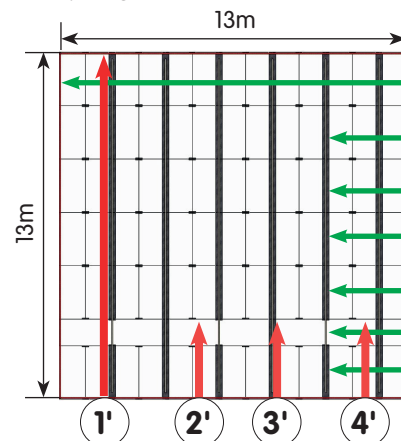

Figure 6 - 13 x 13m th. 5.6cm Complete foam "concertina" tracks Sprung Ex. Floor (Ref.: 6784B)



5/ ⚠ WARNING: TO PREVENT CREASES FORMING, LEAVE TO REST FOR AT LEAST 24 H AT USAGE TEMPERATURE (IF CREASES NEVERTHELESS APPEAR, REFER TO § V). ASSEMBLE THE 4 WIDTHS TOGETHER (SAME METHOD FOR BOTH CARPETS):

Figures 7 - 8 - 9 - Installation of a hook-and-loop joining strip on a carpet width

- Lift each end of a side width (1) finishing with the middle to expose the joining area.
- Unroll a hook-and-loop joining strip (5) (beige & red), without tension, overlapping by 5 cm over the edge of the side width (1).

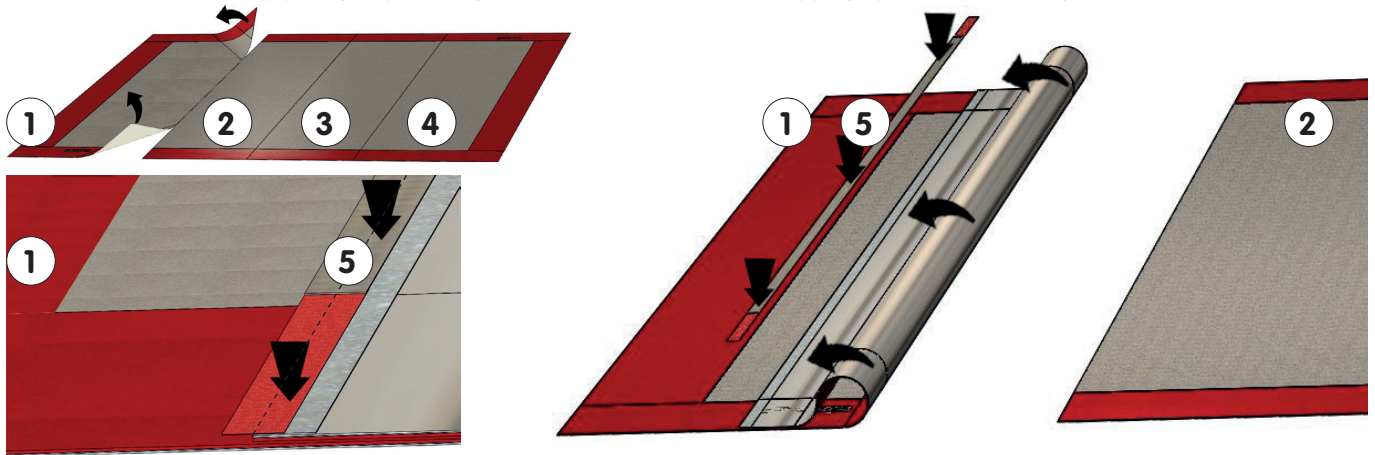

Figures 10 - 11 - 12 - 13 & detail - Finishing the connection of 2 carpet widths

- Fold the side strip (1) with the connecting strip (5) from the middle to the ends.
- Remove the edge of the central width (2) taken below the joining strip (5), lifting the ends until the middle is released.
- Gently rest the middle of the central width (2) identical to the side width, ending with the ends.
- Renew the operation for the remaining widths (3) et (4).
- Cross-check joining strips (5) if necessary (13 x 13m Exercise floors - Refs : 6565K, 6777D & 6777D/DE).

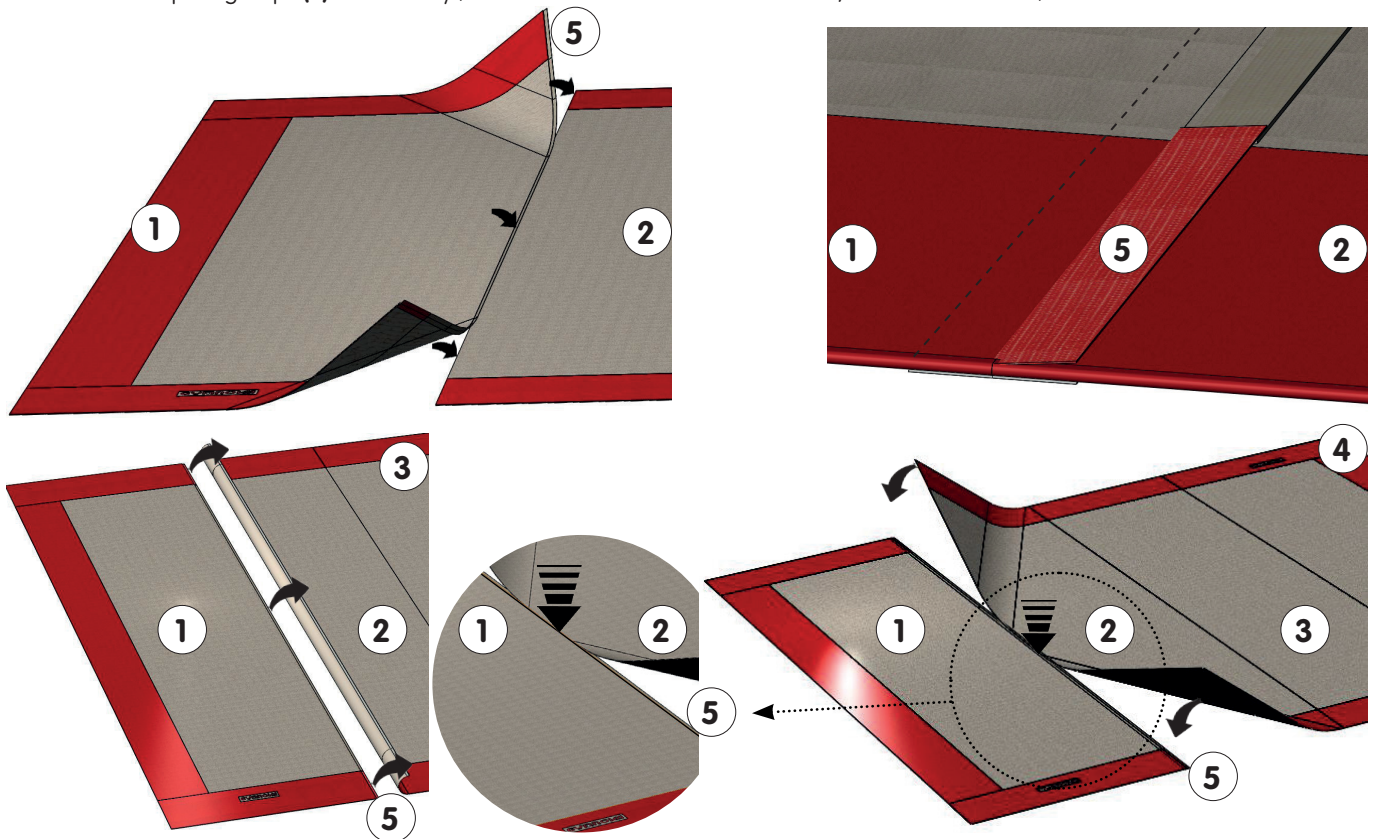

6/ INSTALLATION OF THE CARPET ANTI-ROTATION KIT (8) UNDER THE ENDS OF THE CENTRAL WIDTHS (2) AND (3) (SEE FIG. 14 OPPOSITE).

- Fold back each end of the carpet to expose the black strips (7) underneath the central widths.
- If they are in poor condition, replace them with the ones provided.
- Attach a 2.50 m beige adhesive hook-and-loop strip (6) centred on the width of each black strip (7).
- Remove the protective film from the self-adhesive surface of the hook-and-loop strip (6) and apply the ends of the carpet onto the foam. Press firmly.

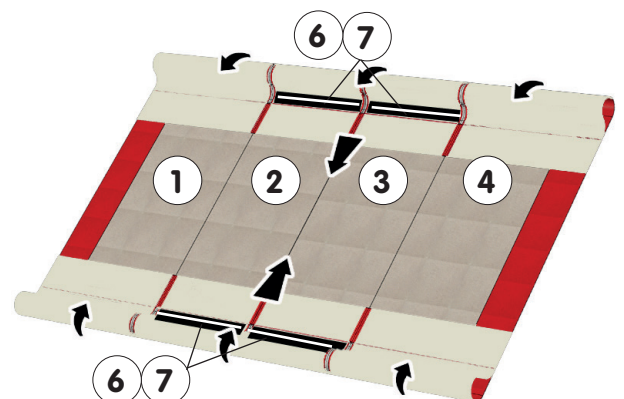

IV. Disassembly and storage of carpet: minimum.

1 / DISASSEMBLY (SEPARATING THE 4 WIDTHS):

- Start by connecting a side width (1) and the central width (2).
- Proceed in the same way for the side width (4) and central width (3).
- Repeat the process between the 2 central widths (2) and (3).

Figure 15 - Separation of 2 widths

- Position yourself at a joint between 2 widths and carefully lift the corner of a side width (1), while holding the corner of the corresponding central width (2): stand on this width, then walking along the join.
- Work in this way up to halfway along the length of the carpet, then repeat this process from the other end: the first side width (1) is now free.

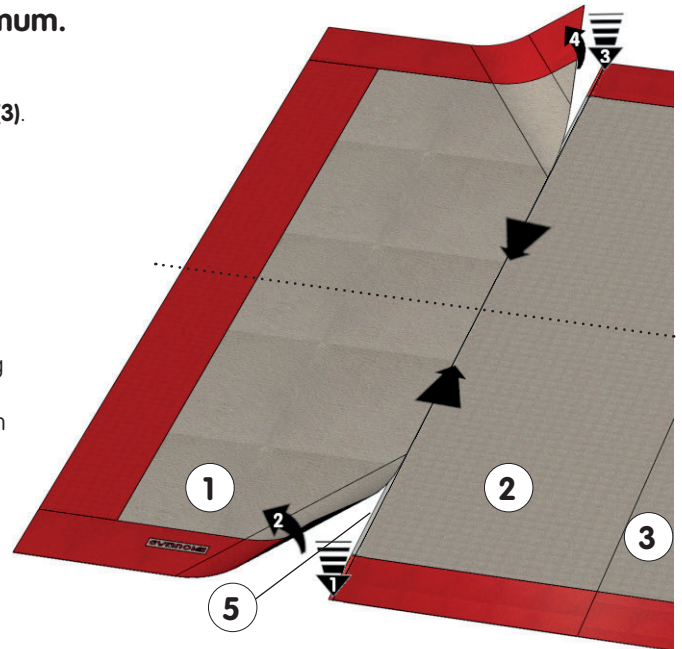

Figures 16 - 17 - Disassembly the joining strip

- Fold back the edge of the central width (2) to release the hook-and-loop joining strip (5).
- Gradually lift the joining strip (5) while keeping the carpet on the floor: standing on the edge of the central width (2), then walking along.

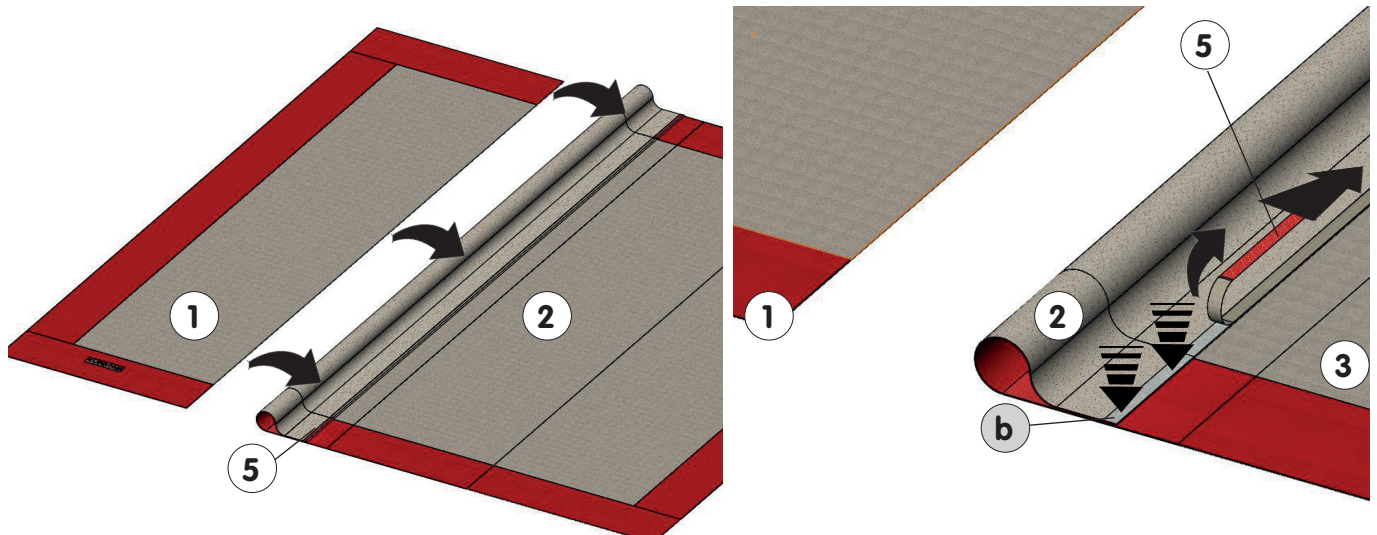

2/ ROLLING THE 4 WIDTHS BEFORE STORAGE:

 **IMPORTANT: THE CARDBOARD CORE TUBE USED MUST PROTRUDE BEYOND EACH END OF THE CARPET WIDTH.**

- Place the 4 widths as flat as possible to facilitate even rolling (do not form a "cone" shape) and to ensure the carpet is stored in good condition.

Figures 18 - 19 - Rolling method

- With 2 people (without a reel trolley), position the cardboard core tube (a) parallel at one end of the first side width (1).
- Roll up the carpet moving forward together at the same time in order to obtain an even cylinder. This will enable the carpet to be stored without damage.
- Repeat the process for the 3 remaining widths.

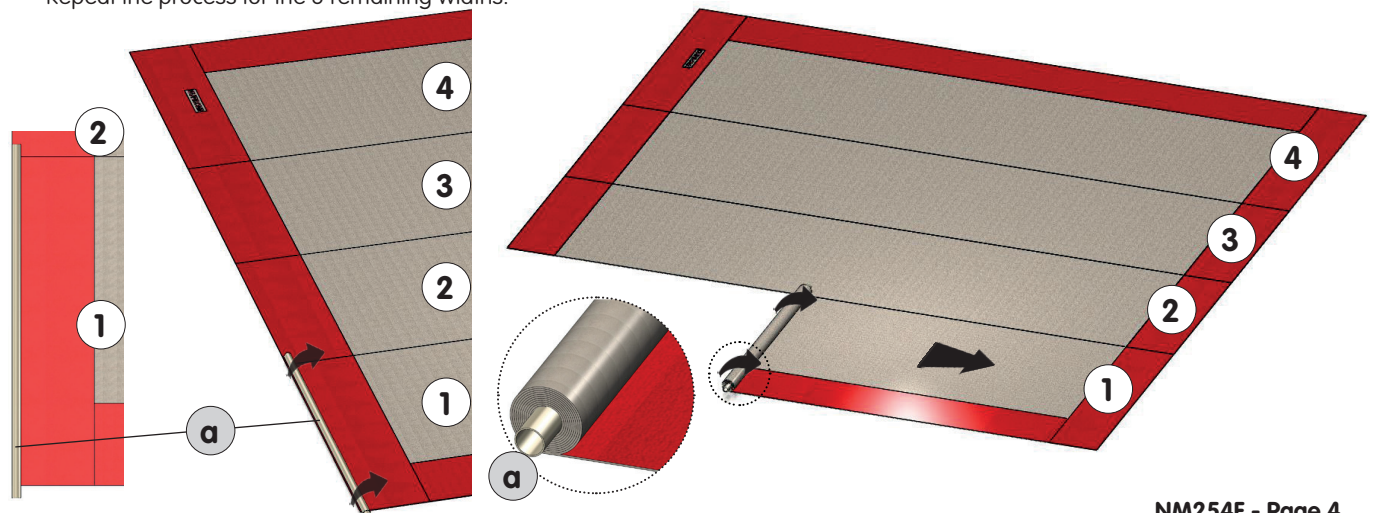

V. Maintenance:

- Regular cleaning of the exercise floor makes it easier to spot any problems (distortion, breakage or moisture absorption).
- Check the condition: of the different carpet widths **(1)**, **(2)**, **(3)** and **(4)** (red edges securely attached to the beige central section, 5cm white hook-and-loop strips **(b)** under the edges of the widths (see Fig 17), the 8 parts of the carpet Anti-Rotation Kit **(8)** and the hook-and-loop joining strip **(5)**.
- For any questions on cleaning the carpet, refer to the recommendations below.
- Check the condition of the "concertina" foam tracks (see NM253, NM299) and the hook-and-loop joining strips **(5)** and the floor (wood & foam blocks - see NM06 or wood & springs - see NM257, NM273 or NM274).
- Any damaged or distorted component should be replaced as quickly as possible.
- If creases appear: remove the joining strips(s) **(5)** from the corresponding width(s) following instructions § IV 1/, and flatten the surface with a cardboard tube **(a)** in the direction of the hair evenly. Allow the carpet to flatten completely, before reinstalling the links according to § III 5/.

VI. Maintenance recommendations:

Maintenance is an essential element in ensuring long life of the carpet. This document gives recommendations on maintenance, stain removal and cleaning for preservation of a high-quality appearance all through the equipment's life.

 **INADEQUATE CLEANING AND IN PARTICULAR USE OF INAPPROPRIATE STAIN REMOVERS OR DETERGENT SOLUTIONS CAN QUICKLY LEAD TO IRREPARABLE DILAPIDATION OF THE CARPET. IN SUCH SITUATIONS, GYMNOVA SHALL NOT ACCEPT ANY LIABILITY.**

Effective maintenance of the carpet MUST include 4 types of actions:

- Protection of accesses
- Dust removal
- Stain removal
- Periodic cleaning

1/ PROTECTION OF ACCESSES: SINCE THE MAIN CAUSE OF SOILING IS DUST AND DEBRIS FROM THE OUTSIDE, PREVENTIVE MEASURES CONSIST IN PROTECTING ALL ENTRANCES TO THE GYMNASIUM.

2/ DUST REMOVAL BY BRUSH-VACUUMING: REGULAR CLEANING WITH A BRUSH-VACUUM CLEANER IS THE PRIMARY MAINTENANCE MEASURE FOR THE CARPET. TO BE EFFECTIVE, IT IS ABSOLUTELY NECESSARY TO USE A VACUUM WITH A ROTATING BRUSH FOR OPTIMAL DUST REMOVAL BY MECHANICAL MEANS, WITHOUT HAVING TO PUSH DOWN WHEN USING THE VACUUM.

3/ STAIN REMOVAL: MUST BE PERFORMED DAILY. STAINS GET MUCH HARDER TO REMOVE WHEN THEY BECOME OLD. PROCEED AS FOLLOWS:

- Liquid stains: As quickly as possible, absorb any spilled liquid by dabbing with a clean, dry and absorbent white cotton cloth. **Do not rub the stain.**
- Solid stains: Remove as much as possible with a knife.
- All stain types:
 - Use the stain removal table below to identify the right stain removal product.
 - Before any cleaning, check that the stain removal agent is "compatible" with the carpet by testing it on an unexposed area.
 - Apply the stain removal product on a white cotton cloth (never directly on the carpet) and dab the stain firmly but without rubbing. Work on the stain from the outside towards the centre to prevent it spreading.
 - Continue to use the stain removal product as described above for as long as it takes for the stain to come out into the cloth.
 - For shampoo-based mixtures, the overturned glass method can be used effectively to massage the stain by making circles with the overturned glass and then collecting any resulting foam in the glass. Repeat the process without adding any product until no more foam is formed.
 - Once the stain is removed, rinse it with clean water by dabbing several times with a damp sponge. Dab with a dry cloth to absorb all the liquid. Warning: some cleaning solutions can give rise to rapid re-soiling if they are not completely removed.
 - Lastly, to absorb residual dampness, place a white, lint-free absorbent layer (cotton cloth or kitchen towel) about 1 cm thick under a heavy object protected with plastic film.
 - After removal of the object, vacuum-brush the area.

4/ PERIODIC CLEANING:

When these operations are properly carried out they can defer the need for more time-consuming operations such as « Major cleaning » or « Renovation ».

- Cleaning using absorbent powder:
 - Spray pre-stain removal solution over max. 10 m² sections at a time concentrating on dirty or stained areas.
 - Then spread the powder into a layer as thin as possible.
 - Use a broom or equivalent to push the powder into the carpet. Leave the product to work for 1 to 3 hours.
 - Remove the powder with a brush-vacuum, passing the vacuum over several times if necessary, without exerting any vertical pressure.
- Injection Extraction :

 **WARNING: THIS VERY COMPLEX METHOD IS A DEEP CLEANING METHOD FOR CLEANING THE FIBRES FROM TOP TO BOTTOM AND SHOULD ONLY BE CONSIDERED FOR EXTREME CASES OF SOILING. FIRSTLY, CAREFULLY REMOVE ALL DUST FROM THE AREA TO BE TREATED.**

The principle of this method is injection of a very dilute solution of detergent in warm or hot water in the case of very greasy soiling which will loosen the dirt. Immediately afterwards, a very powerful wet-suction system extracts the water together with the dirt.

It is important to take care when selecting the detergent solution. **The pH of these solutions MUST be less than 8.**

As a precaution, an anti-foaming agent should be added to the machine's extraction tank.

THESE STEPS SHOULD BE FOLLOWED:

- Proceed using parallel passes. Only use the detergent solution in sufficient quantities to ensure effective cleaning.
- Avoid excessive wetting. Clean in straight lines when possible and overlap each pass by one third of the width of the cleaning nozzle to prevent any residual machine marks.
- After each clean, immediately make a second pass over the same surface without detergent, but operating the vacuum.
- Extraction should be repeated on areas where visible dirt has not been removed by means of a single pass of the cleaning nozzle.
- Next, the same operations should be carried out with water instead of detergent so as to remove all traces of detergent from the carpet pile.
- If extraction has been correctly performed, the optimal drying time is around 6 to 12 hours. Avoid any foot traffic on the carpet during this period. This time period can be significantly reduced by using special blow dryers.

IMPORTANT GENERAL RECOMMENDATIONS:

The carpets are sensitive to chemicals: the fibres in the wear layer and the back of the carpet can be damaged by aggressive agents such as alkaline products (ammonia, etc.), bleaching agents, oxidizing agents (liquid bleach, hydrogen peroxide, etc.) and reducing agents.

⚠️ AVOID SATURATING THE STAIN: PROLONGED OR REPEATED WETTING CAN CAUSE DISCOLOURATION, SOFTENING OR DETACHMENT OF THE BACK, SHRINKAGE, YELLOWING OF THE CARPET OR ENCOURAGE GROWTH OF MOULD AND BACTERIA.

STAIN REMOVAL TABLE*

Type of stain	Actions
Butter, oil, fat, tar, grease, polish	<ul style="list-style-type: none"> - Start by removing as much as possible with a knife. - Dab with a cloth moistened with petroleum type solvent - Then apply an absorbent powder. - Rinse with clean water - Dry and vacuum.
Alcoholic beverages, coffee, tea, soda, fruit juice	<ul style="list-style-type: none"> - After removal of as much as possible with absorbent cloths, - Dab the stained areas (working from the outside towards the centre) with an equal parts solution of water and alcohol. - Then rinse with clean water.
Mud	<ul style="list-style-type: none"> - Leave the mud to dry, then brush. - If necessary, rub with a carpet shampoo solution. - Rinse with clean water.
Candle wax	<ul style="list-style-type: none"> - Remove as much candle wax as possible by lightly scraping. - Then place blotting paper on the stain and apply a warm iron without pressing down. - Repeat, moving the blotting paper, until the wax stain has melted and is mostly absorbed. - Finish by rubbing the stain with a cloth moistened with an alcohol cleaner.
Chewing-gum	<ul style="list-style-type: none"> - Harden the chewing gum with ice - Remove it using the back of a knife blade. - Then dilute what remains with acetone.
Milk, egg, yogurt, chocolate, grass, vomit	<ul style="list-style-type: none"> - Rub with a cloth moistened with hot water and biological washing powder. - Rinse with clean water.
Glue, varnish	<ul style="list-style-type: none"> - Remove as much of the glue or varnish as possible - Then dab with a cloth soaked in acetone.
Paint	<ul style="list-style-type: none"> - Scrape the paint with sandpaper - Then dab with a cloth moistened with acetone.
Lipstick	<ul style="list-style-type: none"> - Clean with a cloth moistened with makeup remover then with a carpet shampoo solution. - Rinse with clean water.
Rust	<ul style="list-style-type: none"> - Dab the stained area with a commercial rust remover. - Before applying, test on an inconspicuous corner of the carpet to make sure it does not cause any discolouration. - Leave to work. - Rinse with clean water.
Blood, milk, sweat, urine	<ul style="list-style-type: none"> - Ammonia solution (28%) or hydrogen peroxide solution (30%).
Nail varnish	<ul style="list-style-type: none"> - Dab the stain with a cloth moistened with acetone or amyl acetate.
Unknown stain	<ul style="list-style-type: none"> - Dab successively with methylene chloride, then acetone, then a dilute white vinegar solution, - Clean with a carpet shampoo. - Rinse with clean water.

* **Remember:** remover must be applied on a clean cloth, NEVER directly on the carpet.

14 x 14m Complete carpet
(Ref.: 6380H)

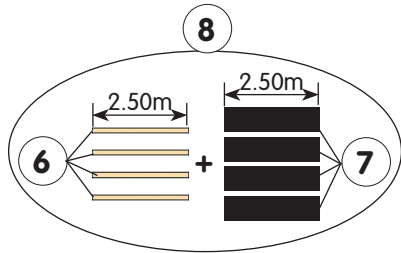
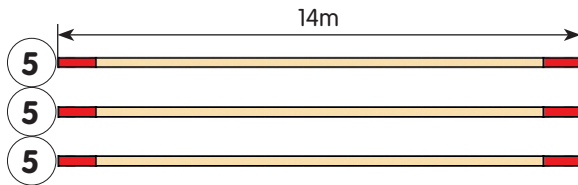
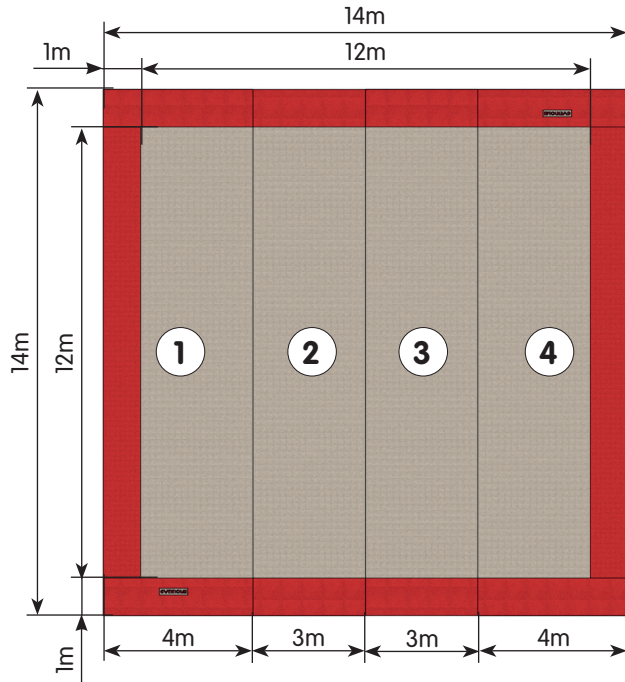

13.05 x 13.05m Complete carpet
(Ref.: 6390I)

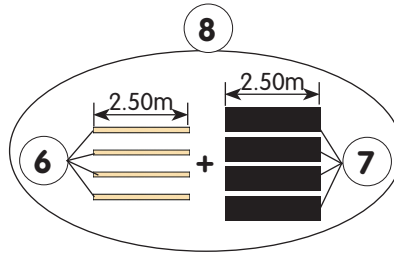
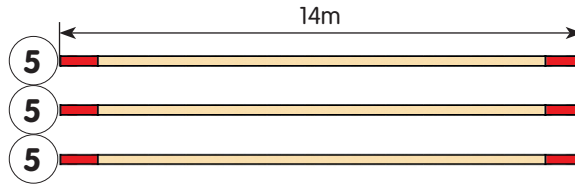
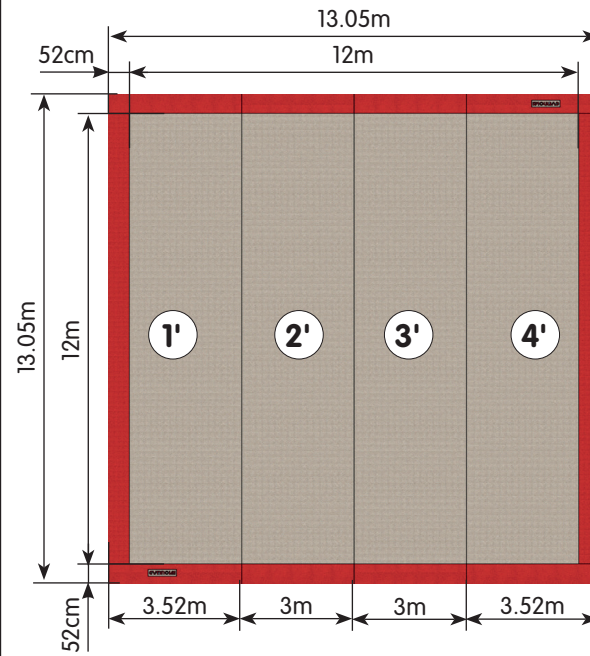

26	-	-	-	-
25	-	-	-	-
24	-	-	-	-
23	-	-	-	-
22	-	-	-	-
21	-	-	-	-
20	-	-	-	-
19	-	-	-	-
18	-	-	-	-
17	-	-	-	-
16	-	-	-	-
15	-	-	-	-
14	-	-	-	-
13	-	-	-	-
12	-	-	-	-
11	-	-	-	-
10	-	-	-	-
9	-	-	-	-
8	1	Carpets Anti-Rotation Kit	6532B	-
7	4	2.50m x 25cm Black adhesive strip	-	Include in 2, 3 & 6
6	4	2.50m x 5cm Beige adhesive strip	-	Include in 8
4'	1	13.05 x 3.52 m Right side width No. 4	6390/144	Ex. Floor 13 x 13m
3'	1	13.05 x 3 m Central width No. 3	6390/143	Ex. Floor 13 x 13m
2'	1	13.05 x 3 m Central width No. 2	6390/142	Ex. Floor 13 x 13m
1'	1	13.05 x 3.52 m Left side width No. 1	6390/141	Ex. Floor 13 x 13m
5	3	14 m Joining strip, beige / red	-	Unit
4	2	14 x 4 m Right side width No. 4	6380/144	Ex. Floor 14 x 14m
3	1	14 x 3 m Central width No. 3	6380/143	Ex. Floor 14 x 14m
2	1	14 x 3 m Central width No. 2	6380/142	Ex. Floor 14 x 14m
1	1	14 x 4 m Left side width No. 1	6380/141	Ex. Floor 14 x 14m
ITEM	QTY	DESCRIPTION	REFERENCE	REMARKS

**14x14M & 13x13M OVERLAY CARPETS
AND ARTISTIC GYMNASTICS EXERCISE FLOORS**

To order spare parts, please provide the description, reference and delivery date of the entire apparatus.

Constantly aiming to improve our products, we reserve the right to make changes to the equipment and dimensions without further discussion.

This document is the propriety of Gymnova, it is confidential and shall not be reproduced.

CLEANUP KITS FOR CARPETS OF A.G. & R.G. EXERCISE FLOORS

6380/125 6380/126

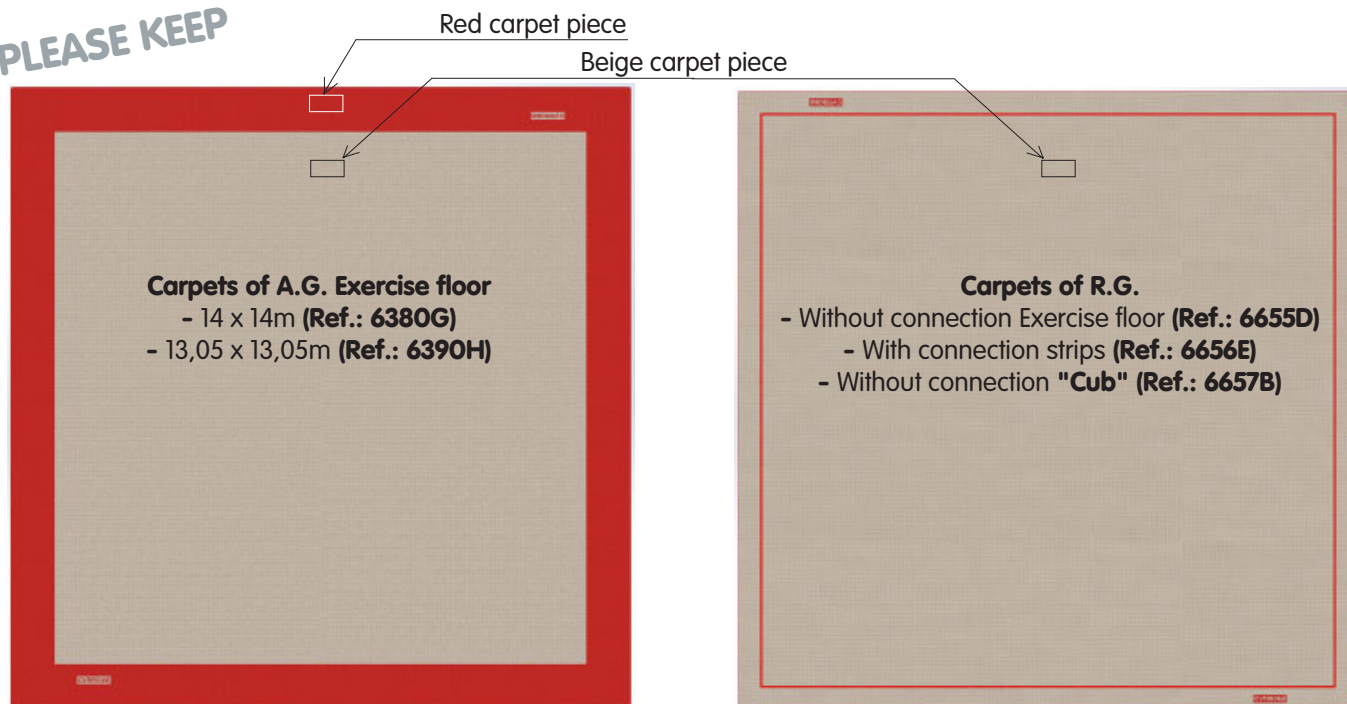
PLEASE KEEP**Warning:**

This operation should be made by a qualified individual.

Using this kit for purposes other than those originally intended don't bind GYMNOVA responsibility.

An irreversible damage may arise if inappropriate stain or cleanup removers are used.

Recommendations:

As set out in French Standard NF S52-400 the following is recommended:

- keep these instructions for subsequent reference (inspection, maintenance, etc.).
- periodically carry out predictive maintenance (see the general instructions of Carpets exercise floors: **NM254** for AG & **NM92** for RG).
- depending on how much it is used, have the equipment serviced yearly or every few years.

Packaging:

Complete cleanup Kit for Carpets of AG & RG Exercise floors -> 1 pack (Ref.: 6380/125) including:

- 20 Beige carpet piece (38 x 18cm)
- 10 Red carpet piece for AG exercise floor (38 x 18cm)
- 1 Litre of cleaning product + 1 Litre spray

Carpet pieces cleanup Kit for Carpets of AG & RG Exercise floors -> 1 pack (Ref.: 6380/126) including:

- 4 Beige carpet piece (38 x 18cm)
- 2 Red carpet piece for AG exercise floor (38 x 18cm)

Cleanup general recommendations:

Avoid scrubbing and flooding the stain (a long or repeated damp may cause the carpet premature fading and ageing).

- 1/ Absorb as quick as possible the spilled liquid by dabbing with a clean, dry and absorbing, white cotton material. If the matter is more solid, begin to take off carefully the most important part.
- 2/ Prepare the carpet piece with the colour matching to the damage part of the carpet: cut a little piece about 10 x 10cm maximum in the carpet piece, according to the area which have to be cleaned off.
- 3/ Relatively soak it.
- 4/ Dab the stained places: clean the stain from outside to center to avoid spreading it.
- 5/ Repeat the operation if necessary, refer to instructions of cleaning product and to the general instructions of Carpets exercise floors: **NM254** for AG & **NM92** for RG.
- 6/ Don't keep the used carpet pieces for another cleanup.

Instructions use of provided cleaning product:

- 1/ Pour 5 cleaning product measuring caps and 1 Litre of cold or warm water into the spray.
- 2/ Foam by applying light pressure rub the surface with a carpet piece or a clean and damp sponge.
- 3/ Leave on the foam until complete drying, then vacuum without pressing to remove residues.